

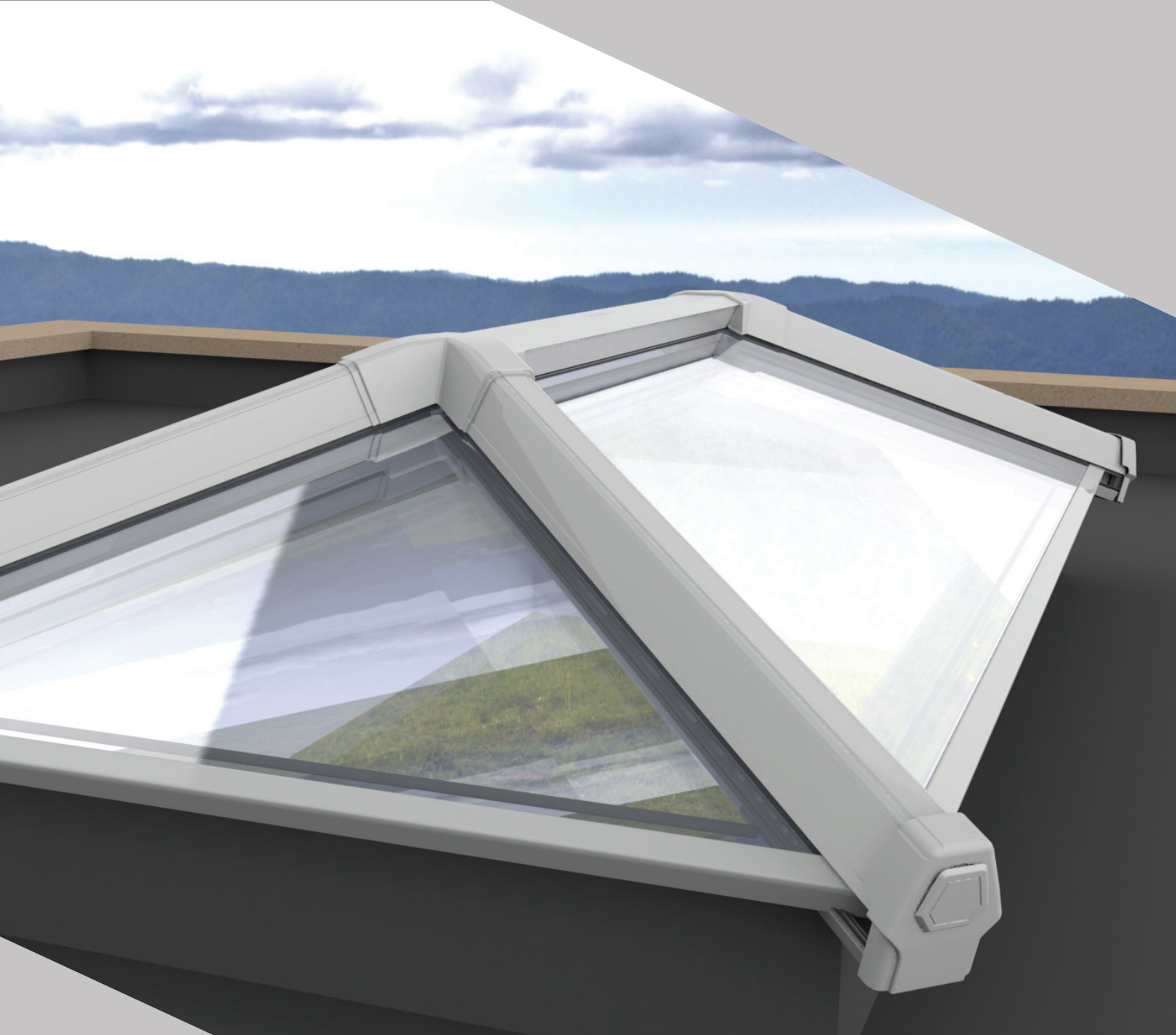

WENDLAND

R O O F S O L U T I O N S



Installation Guide

Wendland Lantern

Thank you for choosing the Wendland Lantern product. This guide is designed to make fitting as straight forward as possible.

This guide is written on the basis that the surveyor has undertaken correct checks for the capability / structural performance of any existing flatroof to verify it is fit for purpose. A timber kerb and weatherproofing materials for the deck/kerb interface are not provided.

Any feedback - positive or negative - is welcome so we can make our systems even better.

**Please contact the Tech Support Team
on 01200 452 318 or email
customerservice@wendland.uk.com**

General points

Care should be taken when handling components that are seen by the homeowner, as surfaces may be scratched if not handled with care. Choose a suitable area for unpacking the components and always check them before fitting. Any claims for missing or damaged parts are only accepted in line with our standard terms and conditions of sale.

Health & safety

Site safety is paramount. The Construction (Design & Management) Regulations 2015 apply to the whole construction process, on all construction projects from concept through to completion. Compliance is required to ensure construction projects are carried out in a way that secures health and safety. The installation company shall be responsible for the safety of all of the fitting team, the customer and members of the public.

The Surveyor should have carried out a risk assessment to reduce risk on site and this should have been discussed with you prior to starting.

Please use safe working platforms and ladders that comply with BS EN 131. Always use equipment in line with

manufacturers recommendations. Personal Protective Equipment –such as goggles, mask and ear defenders – should be used when, for example, grinding out for the flashing.

Careful consideration should be given to the safe disposal of all packaging which can be readily recycled.

Sealing

It is important to use the correct sealant when sealing the roof. Always use MS Polymer sealant such as Rotabond 2000 on self cleaning glass.

The flat roof structure

Check the existing structure is sound and structurally fit for purpose. Check the opening is 'square' and the flat roof deck is level. A timber kerb of 150 x 70mm width should be used onto which is attached the lantern.

Technical Support

Tel: 01200 452 318

Email: customerservice@wendland.uk.com

TOOLS REQUIRED



8, 10, 13mm Socket Spanner



Deadblow Hammer or White Rubber Mallet



No. 2 Pozidrive Bit

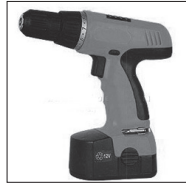

Drill/Screwdriver



Gasket Shears/Snips



4.5mm Drill Bit
10mm Drill Bit



Spirit Level (magnetic useful for internals)



Tape Measure



Box cutter or Stanley knife

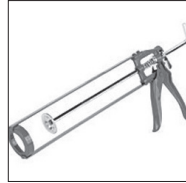

Sealant Gun



Support Prop

**THERE ARE SOME MATERIALS YOU NEED TO SUPPLY:
EG. PLASTERBOARD, 150 X 70MM TIMBER KERB,
FIXINGS TO HOLD ALUMINIUM EAVES BEAM TO TIMBER
KERB**



- Self cleaning glass
- Use the correct sealant on glazing

PAINTED ALUMINIUM PRODUCTS - PLEASE NOTE
All paints will 'chalk' to some extent and there will be a reduction in gloss level over time.
(See Cleaning and Maintenance guidelines see p7)

QUALITY EXPECTATIONS ON INSTALLATION.

Appearance: This is assessed based on the selection of the 'significant' (primary) surface. From a distance of 3m, stand at an oblique angle of 60degree and then defects such as blisters, runs, pin holes etc should NOT be seen.
Colour and gloss: Viewed from 5m, the coating must be of even colour and gloss with good coverage.



1
If storing in warehouse racking or on rails/roof racks, take care to support the products and do not over tension straps and ropes. When opening sealed packs, use a special box knife opener.

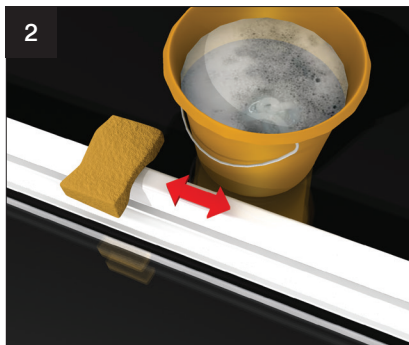

2
Grease marks, dirt and mastic spillage may be removed using soapy water.

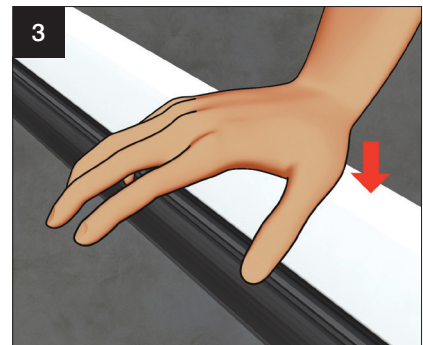

3
Take care when fitting aluminium products to not use excessive force.

PRE INSTALLATION

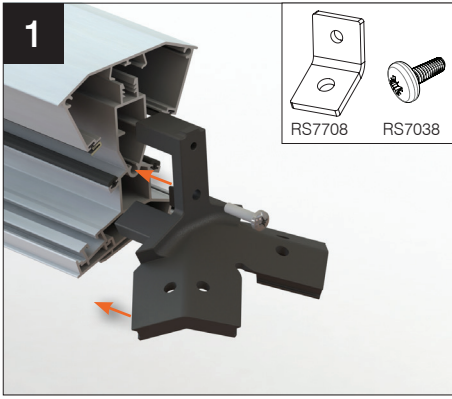

RS7706 is supplied pre-installed into the bar. Remove and fix radius end (S4505BL) then replace the screw. If using 3 bar attach RS7708 using RS7038.

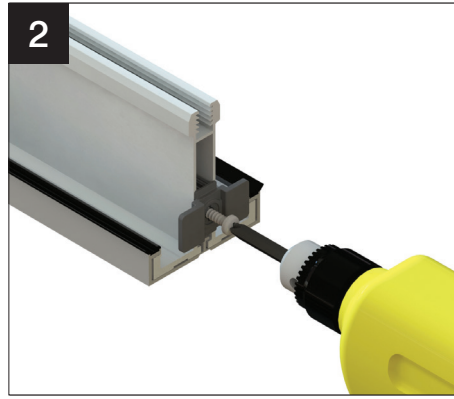

Attach the glazing bar end cap brackets - as access restrictions may prevent easy fixing later.

GENERAL INSTALLATION

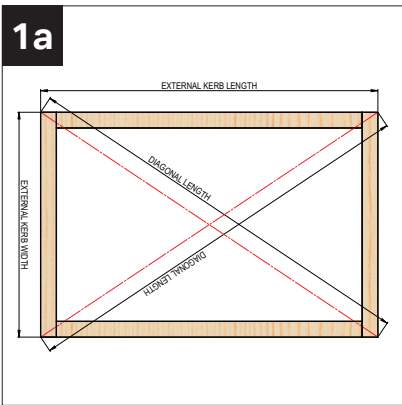

Construct the up-stand to the flat roof with minimum of 150mm tall kerb (minimum of 70mm wide). Check that kerb is square by measuring diagonals. Apply membrane as per manufacturers guidelines.

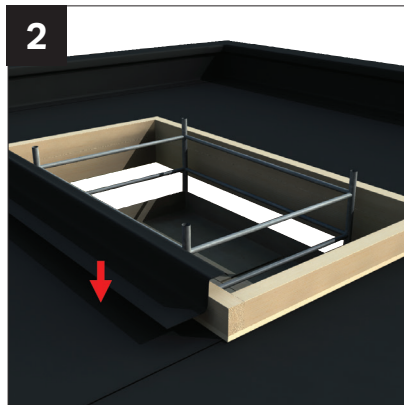

Wrap the membrane up the kerb and lap over the top of the kerb ensuring that a watertight finish is achieved.

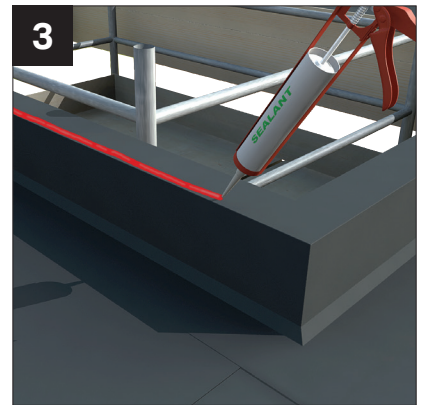

Apply a generous, continuous bead of silicone to the outer perimeter of the top surface of the kerb.



Pre drill 100mm from each end and drill a minimum of 4 holes at a Max of 400mm centres using appropriate clearance drill. Now take the eaves beam/rail and ensure correct number of bolts are slotted into eaves beam/rail.

Minimum of at least 4 screws per eaves beam/rail length.



Cross section of timber kerb with eaves beam/rail in position - note flush with outer edge of kerb.

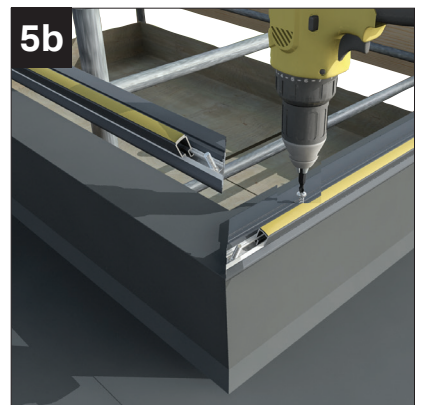

Check the required number of bolts are in the eaves beam/rail. Seal cut ends of eaves. Line up eaves along outer edge of kerb* and screw down using appropriate 5mm x 50mm fixings (not supplied) ensuring good engagement.

*As shown in previous image.

GENERAL INSTALLATION

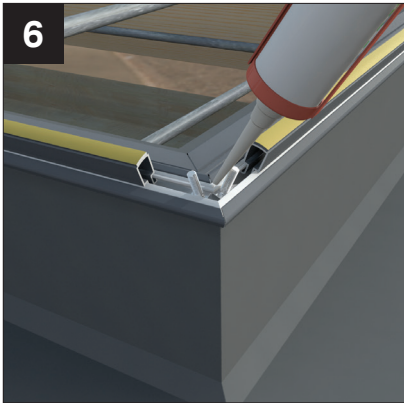

6
Once eaves beam/rail is fitted, silicone corner joints.

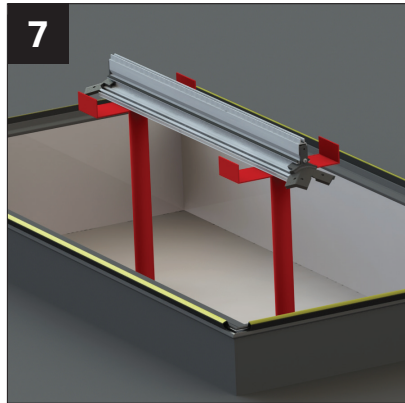

7
Prop ridge in position using suitable supports, centralising between eaves beam sections.



8
Using nuts and bolts provided, locate each hip bar and secure to radius end by hand tightening nuts.

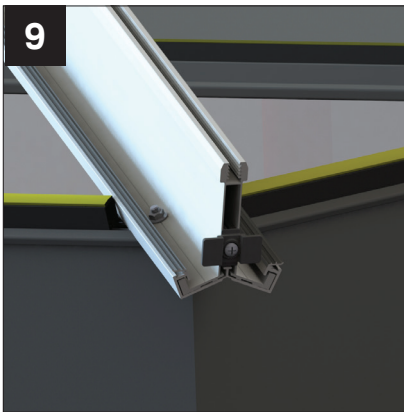

9
Remove nuts on eaves beam. Fit hip bars onto bolts at eaves end and hand tighten nuts.

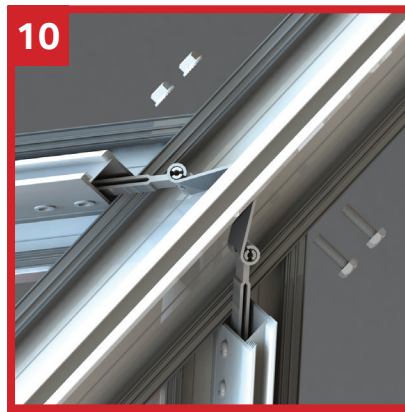

10
If the project contains jack rafters: Offer up the jack rafter to the hip at the pre drilled holes on the hip bar, push the bolts through jack rafter bracket and secure with flanged nuts.

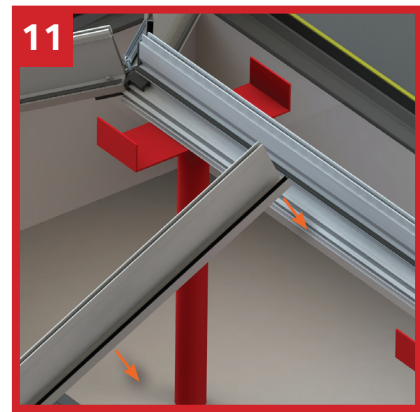

11
If the project contains side Rafters: Locate the rafter on bolts at the ridge and eaves, once in position secure with flanged nuts. Check ridge is level.

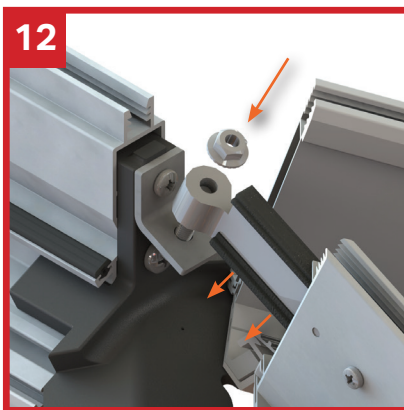

12
If the project contains inter-rafters: Locate the rafter at the radius between the to hip rafters, secure using the 30mm hex bolt and flanged nut provided.

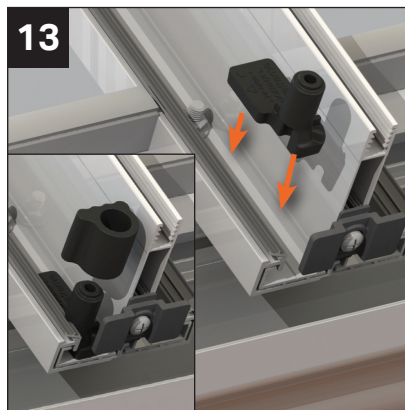

13
Snap off appropriate handed glazing stop. Place this into the base of the glazing bar. Snap off a gromet from the kit, this will slot over the up-stand on the glazing stop. Repeat this for all glazing bars on the roof.

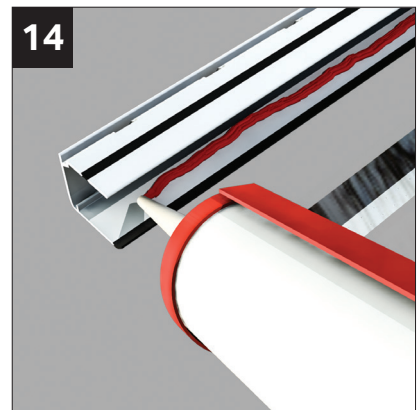

14
MS Polymer sealant only on Self cleaning glass
MS Polymer
Seal underside of top face of glazing end profile as shown (PVCu version of end profile is shown - if aluminium glazing bar top caps, this end profile is also aluminium).

GENERAL INSTALLATION

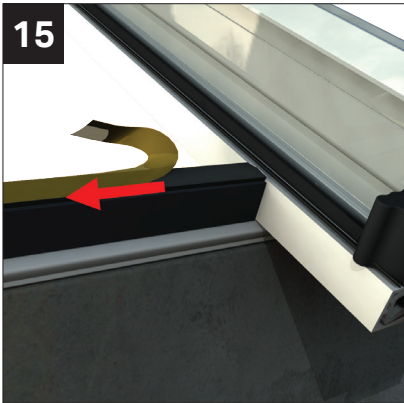

15 Peel back a small tab of the protective film on the glazing support from the eaves.

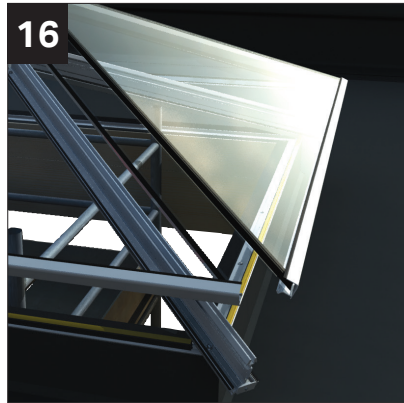

16 Lift glass units into place onto the eaves support trim and lower into place. Ensure that the glass contacts the gaskets on the glazing bars and the ridge. Peel away protective film from glazing support.

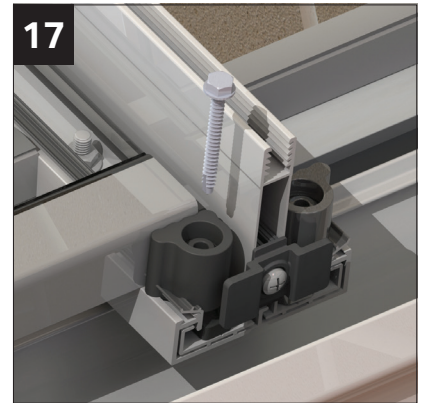

17 Ensure that glazing end profile sits snugly behind grommet, on the glazing end stop. Now using the fixings provided, screw down into the bar as shown.

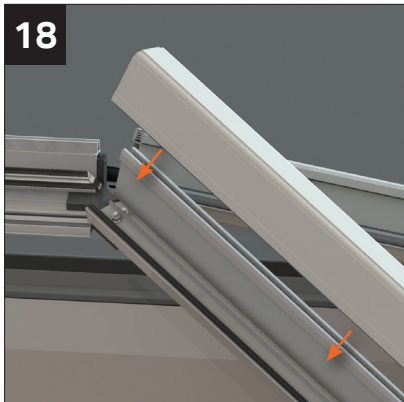

18 Work your way around the roof and fit PVCu glazing bar top caps.

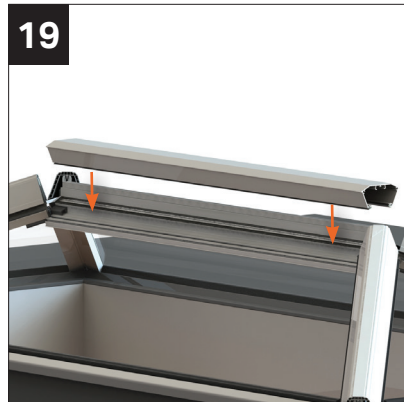

19 Fit the ridge top cap, ensure that the top cap clips are evenly spaced. Push down along the length to check the top cap is fully engaged.

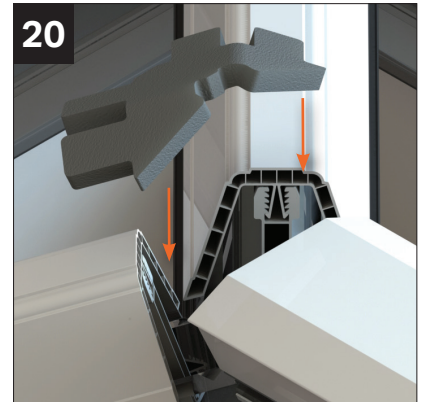

20 **ENSURE THE GLASS IS CLEAN AND DRY BEFORE FITTING.** Peel back protective film from weathering shield and position (adhesive face down) on glass, locating around the ridge and the hip bars.



21 Apply generous beads of sealant to the of the external cover around where the part meets the glazing bar top caps and the ridge top cap.

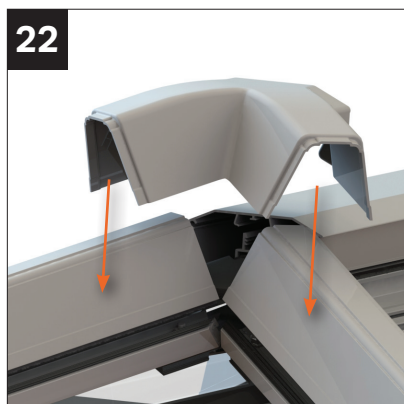

22 Fit the ridge end external cover and press down firmly.



23 Fit end caps to bars and push in the end cap infill.

GENERAL INSTALLATION

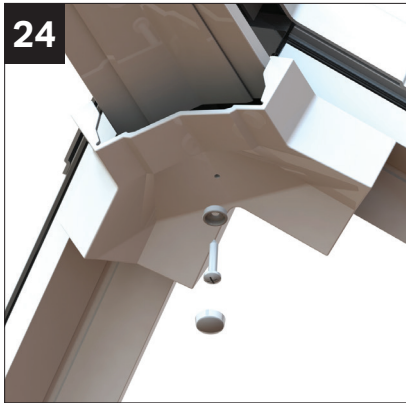

Fit the internal plastic cover, secure by screwing up through the pre drilled holes in the cover and ridge bracket with the screw and cover caps supplied.

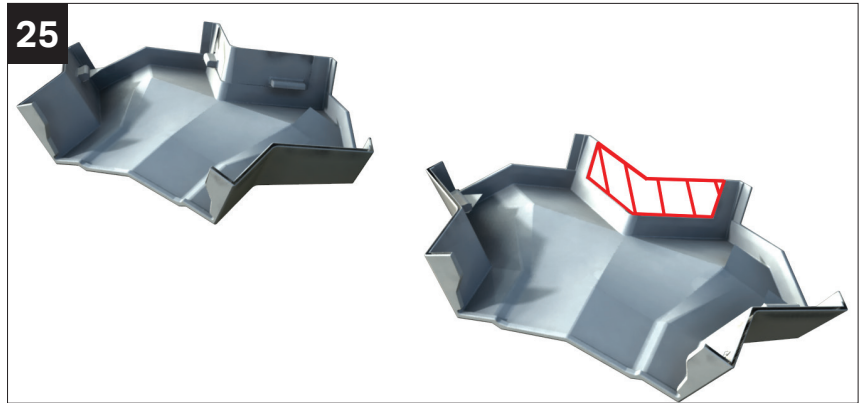

When an inter-rafter between the hips is specified, the internal cover will need the highlighted section above removing using a hacksaw to suit a 70mm glazing bar. Then using pliers remove the section by bending back and forth. Tidy ends using a small file.

CLEANING AND MAINTENANCE - ALUMINIUM EXTERNAL

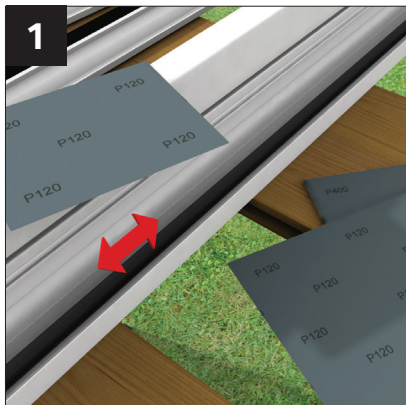

If surface damage is encountered, use 120-360 grit paper to prepare the surface. Wipe clean with white spirit.

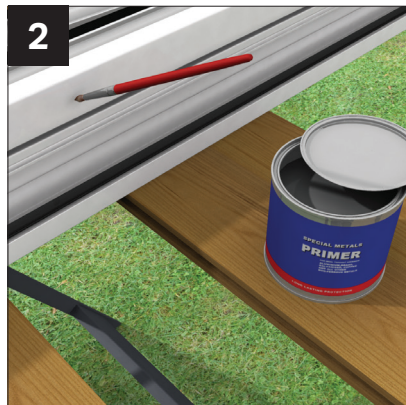

Ensure the surface is dry – apply a thin primer coat using a fine brush.

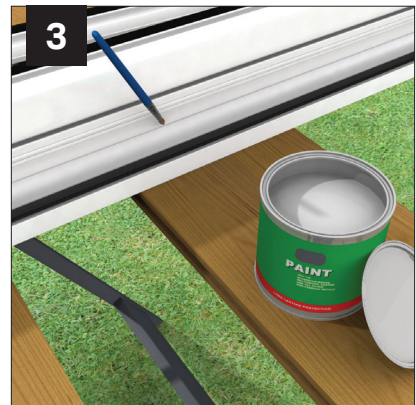

Finally, apply an air drying top coat with a fine brush.

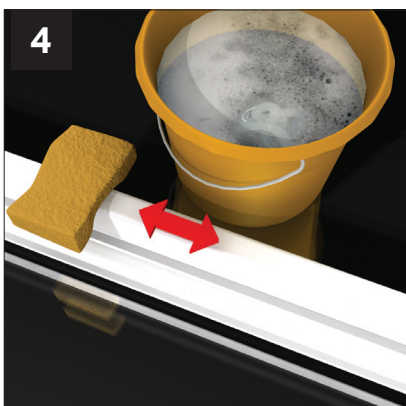

General cleaning can be undertaken by a wash with warm soapy water.

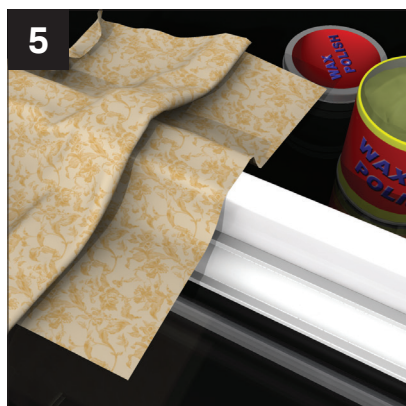

For added protection, a wax polish can be applied up to twice per year – follow the polish manufacturer's instructions carefully.

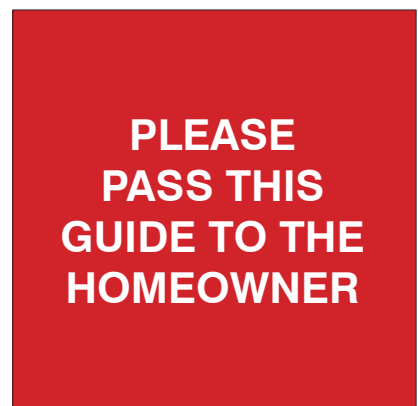

**If in doubt at any stage of the installation
Please contact the Tech Support Team on 01200 452 318
or email customerservice@wendland.uk.com**



WENDLAND
R O O F S O L U T I O N S

www.Wendland.uk.com

© Wendland - Our policy is one of continuous improvement and we reserve the right to change specification and design at any time without prior notice.

Job No. 3877 WENDLAND LANTERN V1 14/05/2018
WLIG001